

## BURNER 577

Clean the outside of the Burner. Unscrew and remove MIXING TUBE 211; the inside of the Burner Body is now exposed. Clean INJECTOR TUBE 212 and ensure that the small Burner holes are not blocked. A BRUSH No. 180 can be supplied for this purpose. If SPIGOT 707 is badly pitted, it should be renewed — unscrew to remove, tighten new one firmly into position. Screw MIXING TUBE into place firmly.

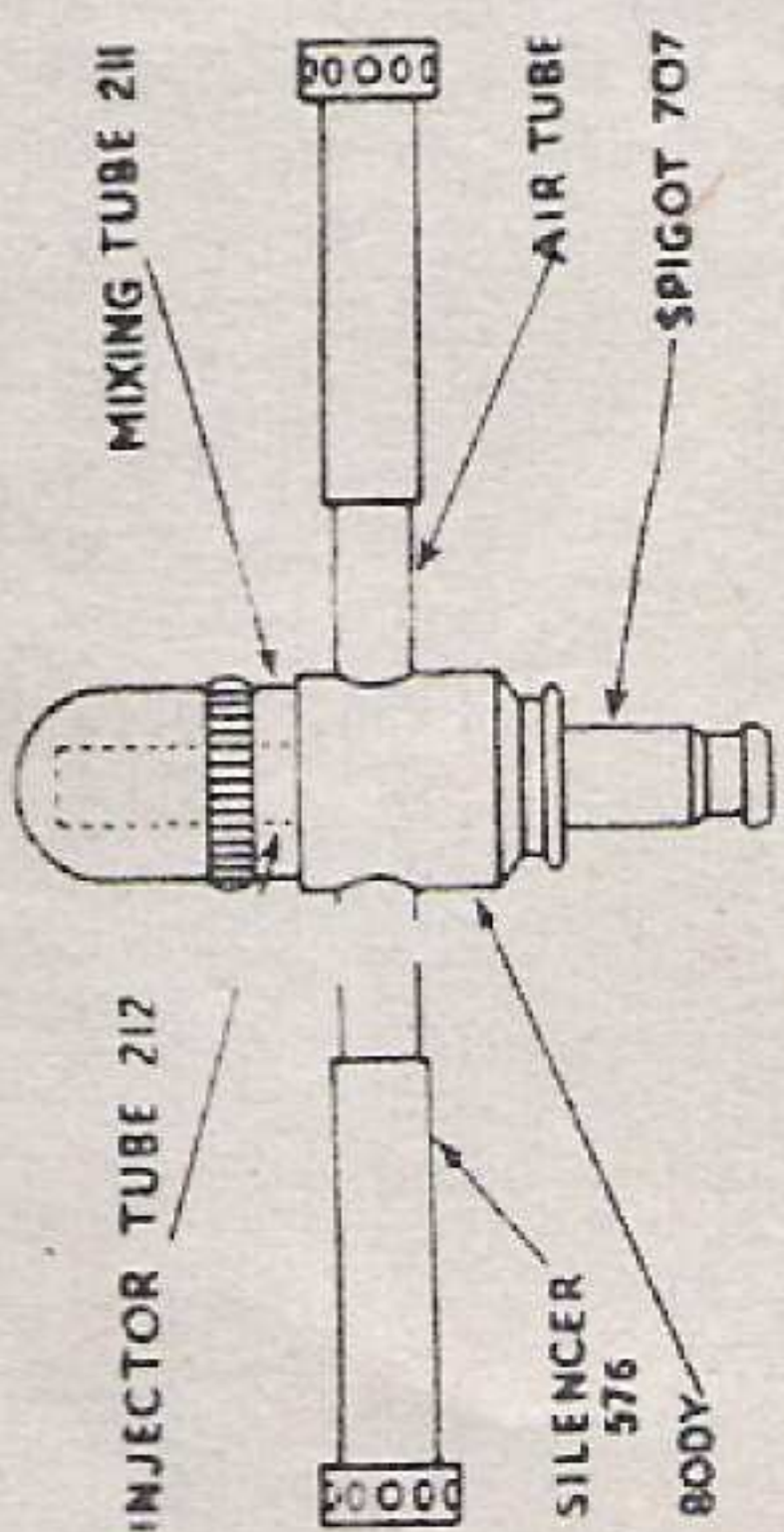

Fit a new TILLEY MANTLE No. 190.

## CONTAINER (see complete Lamp illustration)

See that the FEED ARM is not blocked by observing whether Paraffin (Kerosene) pours out through the FILTER CASE (where the CONTROL COCK fits). Rinse out the CONTAINER with a little Paraffin (Kerosene); empty as completely as possible.

## VAPOURISER 606

The Vapouriser will gradually become choked with carbon and require replacing about every 500 burning hours. Use of clean Paraffin (Kerosene) and the Funnel will ensure that the life of the Vapouriser will be as long as possible.

It is important that the Jet and Cleaning Wire are not interfered with, otherwise the performance of the Lamp may deteriorate.

Vapouriser 606 (5½" long, approx.)



Washer 153

Cleaning Wire 607 (5½" long, approx.)

## CONTROL COCK 2563

Unscrew FILTER 555. Rinse in clean Paraffin (Kerosene) to clean the Gauze. If the Gauze is broken or badly choked, replace FILTER as soon as possible.

Inspect VALVE WASHER 155 and see that it is clean; if badly worn or cut, turn it over or renew. Replace VALVE and SPRING, refit FILTER, tightening firmly.

If the GLAND NUT is loose, lightly tighten with pliers, ensuring at the same time that the CONTROL KNOB SPINDLE is free to move.

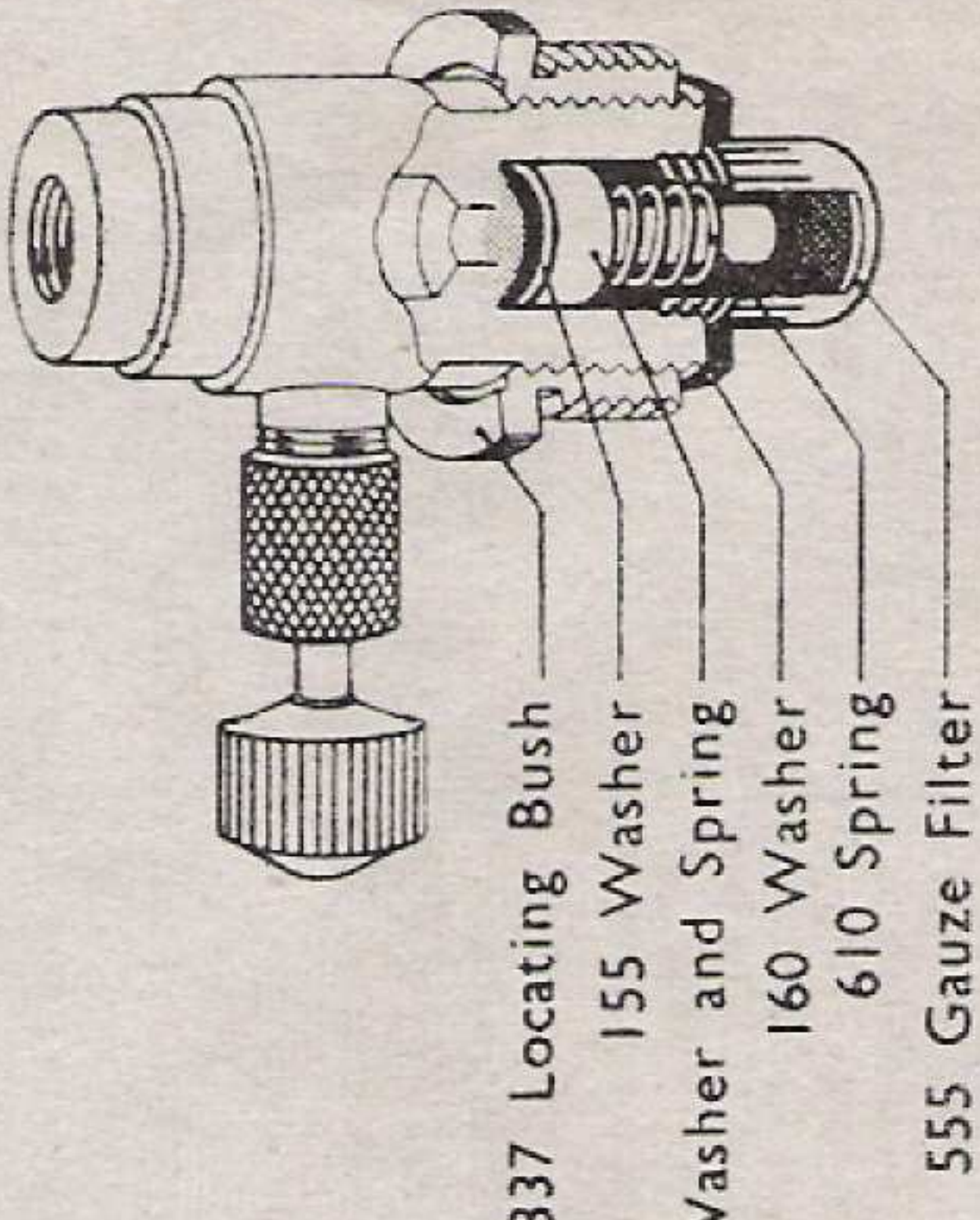

## RE-ASSEMBLY

- (1) Screw LOCATING BUSH 337 on CONTROL COCK as far as it will go, knurled end first. Fit WASHER 160, insert CONTROL COCK in FILTER CASE holding CONTROL KNOB facing to left or right of FEED ARM. Still holding CONTROL KNOB in required position screw LOCATING BUSH into FILTER CASE as far as it will go (finger tight). To finally seal oil joint, rotate CONTROL COCK in a clockwise direction by applying side pressure to the GLAND NUT.
- (2) Turn CONTROL COCK "ON". Screw VAPOURISER into CONTROL COCK; tighten firmly. Make sure the WASHER 153 is in position; do not use more than one WASHER.
- (3) Slide BURNER over VAPOURISER. See that you do not damage the Jet and fine Cleaning Wire at the top of the VAPOURISER.
- (4) Refit SILENCERS to the BURNER.
- (5) Screw PUMP into position.
- (6) The LAMP is now ready for Operation.

TYPE 2669

Printed in England

5M/34/CN&Co.

Hints on the use and care of your

# TILLEY

(REGD.)

## HAND LAMP

Model AL21



This Lamp operates on Paraffin (Kerosene)  
NOT Petrol (Gasoline)

MANUFACTURED BY

THE TILLEY LAMP COMPANY LTD.  
15 SACKVILLE STREET, LONDON, W.1.

# Use Paraffin (Kerosene) Do Not Use Petrol (Gasoline)

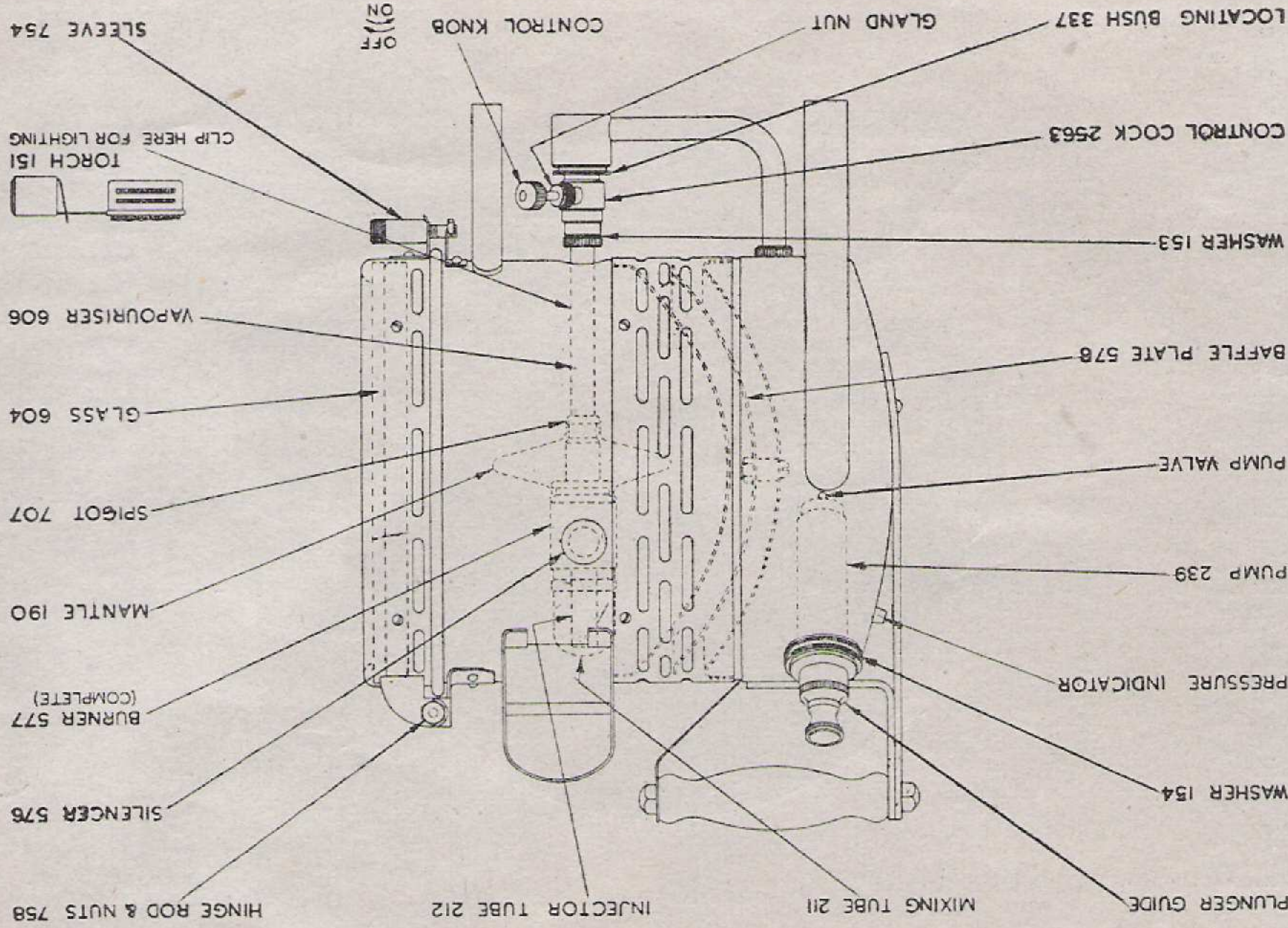

## PRINCIPLES OF LIGHTING

It is necessary first to understand that TILLEY Lamps operate on Vapourised Paraffin (Kerosene).

The purpose of the pre-heating is to heat the Burner and Vapouriser, so that when you release the flow of paraffin (kerosene) it changes from a liquid to a vapour and burns as a gas inside the Mantle.

Consequently, if you turn on the flow of paraffin (kerosene) too soon, it will be a liquid and burn with a flame, so if this happens you need only close the Cock again and the flow of paraffin (kerosene) will cease.

Also, if you pump too violently at the beginning, there will be more paraffin (kerosene) forced up than can be vapourised when the Lamp has not had time to warm up very much, and this will also cause a flame, which can be easily stopped by turning the Control Knob back to "OFF".

In either case release all air by unscrewing the Pump and pre-heat a second time.

You will soon get the knack of lighting the Lamp easily with the first pre-heating.

## HINTS FOR CARE OF LAMP

When filling the Lamp always use the Funnel provided, because this Funnel has a gauze in it which will strain dirt. Also, be sure that you keep your paraffin (kerosene) in a clean can.

When the Lamp is not in use you will, of course, have already extinguished it by turning the Control Knob to the "OFF" position. There is no need to release the pressure when extinguishing, but as you will have seen from the instructions, there should be no pressure in the Container when you start to re-light the Lamp, so simply unscrew the Pump and release the pressure, taking care to tighten the Pump again. It is always useful to make sure before lighting the Lamp that there is sufficient paraffin (kerosene) remaining in the Container. While the Lamp is in use it is possible for carbon from the paraffin (kerosene) to get into the Jet, and the jet is simply cleaned by turning the Control Knob "OFF" and "ON" quickly while the Lamp is alight.

Do not let the Lamp burn on a very low pressure, because if you do the vapourised paraffin (kerosene) may not be forced up sufficiently strongly into the Burner, and "lighting back" may occur, which will be observed by a roaring noise. This is detrimental to the Mixing Tube and if allowed to continue will burn it through. To overcome "lighting back", simply turn the Control Knob "OFF" quickly, and give more pressure by pumping.

Do not use broken Mantles, because the naked flame may discolour the Reflector and break the toughened glass.

The joints of TILLEY Lamps are only required to be hand tight, that is to say, it is not necessary to use pliers. It is a good thing to go over the joints from time to time and make sure that they are tight, also to inspect the Washers (which should be clean).

There is also a Washer in the valve of the Pump which should be inspected from time to time, as if this is worn or dirty the Valve will not shut properly and paraffin (kerosene) will get into the Pump Barrel and be ejected when you use the Pump.

If the light from the Lamp is poor this may have been caused by carbon in the Jet of the Vapouriser as referred to above. If it is not improved by operating the Control Knob, then it is probable that the life of the Vapouriser is over and a new one should be fitted.

When re-ordering Spare Parts from your Dealer, always refer to the numbers on the illustrations shown on this sheet. This will prevent any mistakes.

## COMPLETE OVERHAUL

If you wish to completely overhaul your Lamp, the following is the method, unless you prefer to have this done by your Dealer. In any case, the procedure for dismantling is as follows:

Always proceed in the order given below:

- (1) Unscrew and remove the Pump.
- (2) Empty all PARAFFIN (KEROSENE) from the CONTAINER.
- (3) Turn CONTROL KNOB to the "ON" position.
- (4) Unscrew and remove SILENCERS 576 from the BURNER 577.
- (5) Lift BURNER from the VAPOURISER.
- (6) Unscrew and remove VAPOURISER 606.
- (7) Unscrew CONTROL COCK as far as it will go then remove from Filter Case by unscrewing Locating Bush 337. Proceed to overhaul as follows:

### PUMP 239

Unscrew PLUNGER GUIDE 55 and remove PLUNGER 238 from PUMP. Inspect LEATHER 120 and ensure that it is soft and not puckered. If too hard, apply a little lubricating oil. See that the HEXAGON NUT 121 is tight. Unscrew VALVE GUIDE 612 and inspect VALVE WASHER 155. See that it is clean. If badly worn or cut, turn it over or renew.

Replace VALVE and SPRING and tighten VALVE GUIDE.

See that the rubber WASHER 154 is clean and not twisted or broken.

To renew WASHER 154, pick out the whole of the old Washer with the blade of a penknife. Fit the new Washer, slide it over the Barrel of the Pump until it is nearly in its correct position.

Insert the Pump Barrel into the Collar of the Fuel Container; push hard on the Pump and screw into position firmly by hand.

Pump Plunger 238

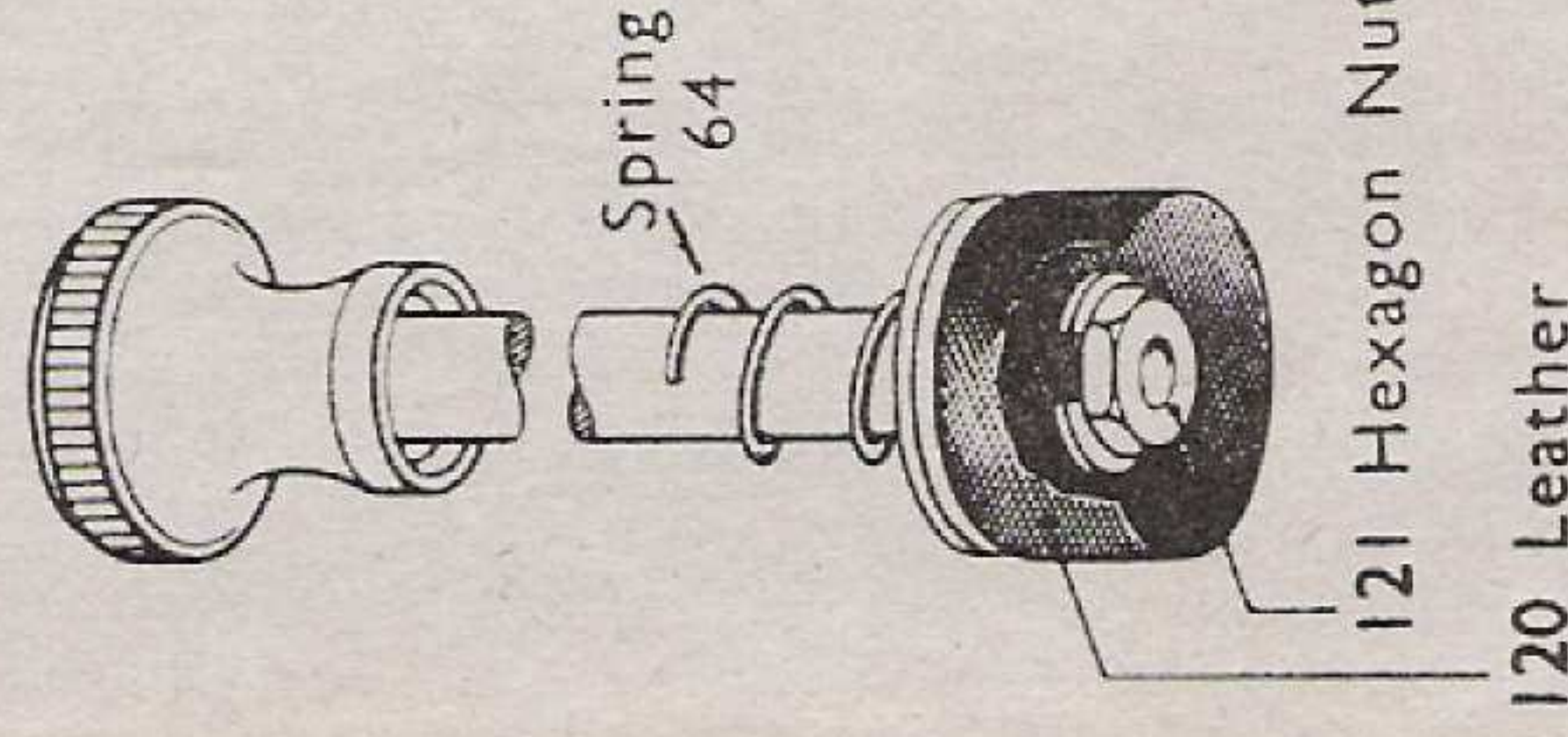

Pump 239

